

✓ **Applications**

Range of Dead weight tester is designed to test, adjust and calibrate measuring instruments, mechanical or electronic pressure by comparison (pressure gauges, pressure transmitters or sensors or switches)

They are constituted by a generator of pressure, connected to a compressed source of air, a unity piston/cylinder, of a set of weight identified and of a computer on which is posted : the position of the piston and the value of pressure generated by the dead weight according to the various physical quantities.

The capstan allows to adjust the pressure by compressing the gas through the piston. This pressure is balanced by the set piston/cylinder what allows to compare the instrument to be calibrated in the values of pressures generated by the standard and indicated on the calculator. These dead weight are intended for the calibration in relative pressure.

The Dead weight are robust and easy to use and have a high long-term stability.

✓ **Technical specifications**

- **Calibration :** It is necessary to recalculate the pressure generated by the dead weight according to the different variables. Our dead weight are calibrated in the following terms of use :  
Temperature 20°C - Pressure atmos. 1013.25 hPa - Humidity 50% - acceleration 9.80665 m/s<sup>2</sup>
- **Fluid :** The system of automatic lubrication integrated into the dead weight avoids the risks of contamination piston/cylinder. Colorless, compatible mineral oil with medical or food uses - volume of the reservoir 20 cm<sup>3</sup>
- **Source Pressure :** Dry air - gas connection ¼ cylindrical female - This balance needs to be connected to a pressure source.
- **Check/adjust the seat :** leveling bubble and adjustable feet
- **Connection for the instrument to be tested :** swivel G1/2 standard
- **Motorization :** training the weight in rotation by electric engine
- **Measure of the temperature :** Precision ± 0.1°C
- **Measure of the atmospheric pressure :** Precision ± 1hPa
- **Measure of the hygrometry :** Precision ± 10%
- **Calculator :**
  - with dynamic display of the position of the piston
  - with automatic display of the pressure generated by the dead weight according to the temperature, the atmospheric pressure and the hygrometry
  - with a connection for the transfer of the data on computer, allowing a total traceability
- **Carter :** Light alloy aluminium AG3 + high-resistance paint
- **Ratchet :** removable for transport
- **Piston/cylinder :** Single piston treated stainless - **Répeatability** : 1.10<sup>-5</sup> - **Sensitivity** : 0,5.10<sup>-5</sup> - **Precision dead weight** : 5.10<sup>-5</sup>
- **Weight :** corrosion treated steel - **Weight** of the set of weights from 33 kg to 48 kg depending on model – Shape masses ergonomic, easy loading of the masses on the bell - **Marking** corresponding with the measuring unit (bar, mbar, KPa, PSI etc..)

✓ **Specific Model**

- **Model :** BA4-60B - dead weight simple piston
- **Measuring range :** 0.5 to 60 bar / 5 to 800 PSI / 50 to 6000 kPa
- **Accuracy dead weight:**  $0.00025 + (0.5 \cdot 10^{-4} \times P)$  (with P en bar)
- **Weight dead weight without weight :** 22 kg
- **Typical cross-section of the piston :** 78.4825 mm<sup>2</sup>
- **Material piston/cylinder :** stainless steel
- **Number of piston :** 1

✓ **Various**

- **Manuel :** a detailed operating instructions supplied with the device + Certificate + 0.5 liter oil
- **Maintenance :** Our technical department is at your disposition for the revision, calibration or service your unit – Calibration device recommended every 2 years

✓ **Dimensions of device**

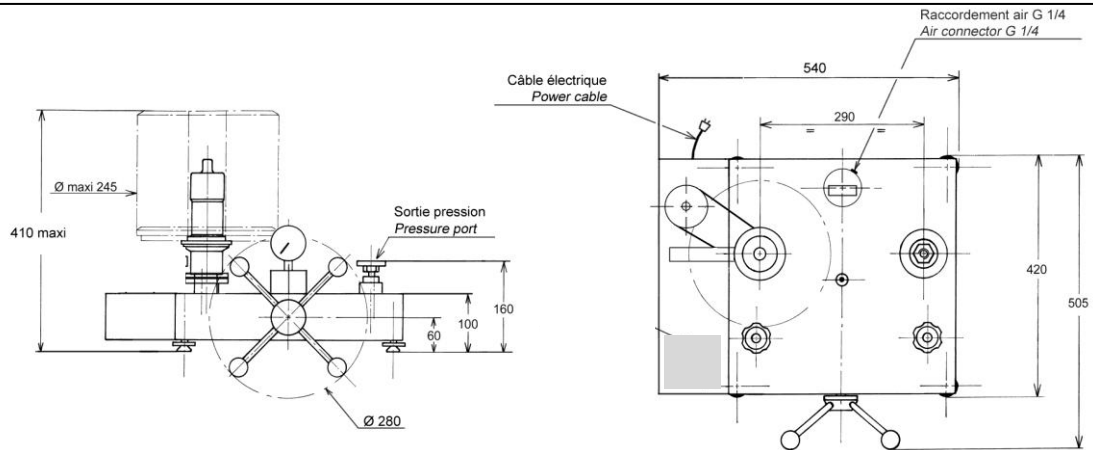

Height with standard set of weight : (bar, kPa) : 411 mm (PSI) : 386 mm

Unit used : mm

✓ **Standard weight sets and intermediate** (for other units contact us)

Standard set			
	Pressure (bar)	Total weight	Typical value (g)
<b>Unit : BAR</b> (Ref. MB0001)	10	4	8000
	9.5	1	7600
	5	1	4000
	2	2	1600
	1	1	800
	0.5	1	400
Initial Pressure bell + weight adaptation	0.5		400
<b>TOTAL</b>	<b>60</b>	<b>10</b>	<b>±48 kg</b>

Intermediate set			
	Pressure (bar)	Total weight	Typical value (g)
<b>BAR</b> (Ref. MB0002)	0.2	2	160
	0.1	1	80
	0.05	1	40
	0.02	2	16
	0.01	1	8
<b>TOTAL</b>	<b>0.6</b>	<b>7</b>	<b>480 g</b>

Standard set			
	Pressure (PSI)	Total weight	Typical value (g)
<b>Unit : PSI</b> (Ref. MB0013)	100	6	5520
	95	1	5244
	50	1	2760
	20	2	1104
	10	1	552
	5	1	276
Initial Pressure bell	5		276
<b>TOTAL</b>	<b>800</b>	<b>12</b>	<b>±44 kg</b>

Intermediate set			
	Pressure (PSI)	Total weight	Typical value (g)
<b>PSI</b> (Ref. MB0016)	2	2	110.6
	1	1	55.2
	0.5	1	27.6
	0.2	2	11
	0.1	1	5.5
<b>TOTAL</b>	<b>6</b>	<b>7</b>	<b>331.5 g</b>

Standard set			
	Pressure (Kpa)	Total weight	Typical value (g)
<b>Unit : kPa</b>	1000	4	8000
	950	1	7600
	500	1	4000
	200	2	1600
	100	1	800
	50	1	400
Initial Pressure bell + weight adaptation	50		400
<b>TOTAL</b>	<b>6000</b>	<b>10</b>	<b>±48 kg</b>

Intermediate set			
	Pressure (Kpa)	Total weight	Typical value (g)
<b>kPa</b>	20	2	160
	10	1	80
	5	1	40
	2	2	16
	1	1	8
	<b>TOTAL</b>	<b>60</b>	<b>7</b>

✓ **Options for weight set**

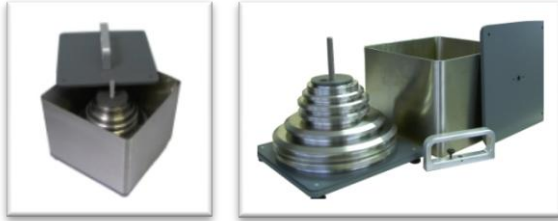

transport metal boxes  
(OP0101) : 260 x 260 x 310 mm - weight empty : 6 kg



Suitcase for post planning and shipping  
(OP0095) small : 280 x 250 x 280 mm - weight empty : 5 kg  
(OP0099) large : 500 x 350 x 280 mm - weight empty : 11 kg

Useful for BA4-60B : Consult us !

✓ **Options**

- Weight set additional base for different units
- Adjust the dead weight with a different acceleration of 9.80665 m/s<sup>2</sup> on request
- Calibration of the instrument : Points statement AREMECA or certificate of calibration DAkKS or COFRAC
- Degreasing oxygenates optional (consult us)

✓ **Shipping and packaging**

- **Packaging** : woodpack is provided for the shipping

Designation/Reference	Dimension / carton or shipping crate	Weight empty / total weight (packaging + materiel)
<b>Dead weight without weight</b>	470 x 470 x 240 mm	Carton empty 1.5 kg Total weight ±24 kg
<b>Standard weight set</b>	300 x 300 x 170 mm	Carton empty 1.5 kg Total weight ± 51 kg
<b>Wood packaging</b> SB0003	980 x 700 x 500 mm	Suitcase empty 20 kg Total weight ± 95 kg (dead weight + weight set + packaging)



SB0003

- **Note** : shipping is extra.

✓ **Other models available in the range BA4**

(Datasheet is available on request)

Models simple piston

Models	Accuracy	Measuring range		
		Bar or kg/cm <sup>2</sup>	PSI	kPa
BA4-200B	10 <sup>-4</sup>	5 to 200	50 to 3000	500 to 20000
BA4-120B	10 <sup>-4</sup>	1 to 120	10 to 1600	100 to 12000

✓ **Accessories** (Ask for our specific documentation)

- Accessory case (ref.OP0057)
- Setting gauge kit (ref.OP0125)
- Case connectors M (ref.OP0174) – Case connectors G (ref.OP0171) - Case connectors NPT (ref.OP0172) - Case connectors BSP-TR (ref.OP0173) - Case with 17 connectors M + G + NPT + BSP-TR (ref.OP0037) – unit connector (consult us)
- Carrying case for dead weight (ref.OP0002)